

DAY 6 TUESDAY, 28 JANUARY 2025

SHOWDAILY™

The Daily News of IMTEX 2025

Organiser



Indian Machine Tool
Manufacturers' Association



International Machine Tool &
Manufacturing Technology Exhibition

Concurrent Shows



International Exhibition of Cutting Tools, Tooling Systems,
Machine Tool Accessories, Measuring & QC/CIM



International Exhibition on
Digital Manufacturing Technology

23 - 29 January 2025 · BIEC, Bengaluru



Scaling new heights
in manufacturing

powRgrip® System



Booth #B108
Hall 3A

The fastest tool clamping
system in the world

www.rego-fix.com

REGO-FIX



Complete Automation Solution for Machine Tool Industry.

Delta presents its IoT-enabled automation products and solutions, delivering exceptional performance and reliability. **Discover the cutting-edge NC5 CNC controller through live demonstrations that highlight its advanced features and superior capabilities.**

Drive, Motion Control, Power Quality, HMI, PLC, CNC, Sensor, Meter, Field Device, Servo Press, Power Supply, Temperature Controller, Robot Solutions, Software like SCADA and Industrial EMS for complete smart manufacturing solutions.

Fastest Growing Automation Brand in India



BIEC, BENGALURU
23-29 Jan 2025

Hall No.5
Stall No.B103



automation@deltaww.com | www.deltaelectronicsindia.com

Precision Machining.

Together.

Hall No-5 Booth No: A 129

quakerhoughton.com | info@quakerhoughton.com



MACHINE TOOLS, LASER MACHINES, & AUTOMATION SOLUTIONS

Mazak's Vision for India's Manufacturing Future

At IMTEX 2025, one of Asia's premier machine tool exhibitions, Takashi Yamazaki, President, Yamazaki Mazak Corporation, discussed the company's innovations, vision, and strategies for a market poised for significant growth. He also highlighted Mazak's commitment to addressing the evolving needs of Indian industries, from traditional manufacturing to high-tech solutions for EV and renewable energy sectors.



Source: Marie Ward Media

Mazak recognized India's potential as a growing market for the machine tool industry as early as 1998, well before the industrial boom, starting with technology centers for providing after-sales service, technical assistance, and spare supplies to Indian customers. Over the past 27 years, Mazak's installations, sourced from Japan and Singapore, have significantly increased. "Now, we believe, the time is right to manufacture machines in India, offering high-quality solutions tailored to Indian customers," said Yamazaki.

Mazak's evolution in India reflects its understanding of the market's dual needs—serving both high-end and commodity segments. "We aim to ensure Indian manufacturers have access to reliable machines, which helps smaller customers scale their businesses and eventually transition to advanced machinery," he added.

Demand for High-End Machines

According to Yamazaki, there has been a shift in demand. "While commodity machines remain essential, industries like aerospace, medical, and semiconduc-

tors require more sophisticated systems to enhance productivity and output. Automation is also becoming a critical component. For example, large corporations in India are increasingly investing in high-end machines paired with automation to stay competitive." He emphasized the need to cater to both segments simultaneously. "We will never abandon commodity machines. These entry-level solutions introduce customers to Mazak's reliability. As their businesses grow, they often opt for

To be continued on 4 ▶

AceMicromatic
Group

All You Need In
Machining

40+
EXHIBITS
ON DISPLAY

25,000 sq ft
DISPLAY
AREA

Visit us

@



Hall No:
05

Stall No:
B109

acemicromatic.net

IMTEX 2025
Achieves
Record-
Breaking
Footfall



Source: Magic Wand Media

» We don't just make machines; we build relationships. By showcasing technology and engaging directly with customers, we ensure Mazak remains their top choice.«

Takashi Yamazaki
President
Yamazaki Mazak Corporation

higher-end systems. This two-pronged approach ensures long-term growth for both Mazak and our customers.”

EV Manufacturing: Opportunities and Challenges

According to Yamazaki, India is already making strides in the EV manufacturing, but he sees a room for growth. “Globally, over 50 percent of our automotive business in China caters to EVs, but this trend hasn't fully materialized in Japan or India. While EVs are promising, hybrid engines remain a practical choice for many markets.” Mazak, he shared is ready for the EV revolution. “We have developed dedicated machines for EV components, such as subframes for giga castings, ensuring we stay ahead of market needs. Although the EV demand is quieter now, we are preparing for the next wave by offering tailored solutions to manufacturers.”

Role of Renewable Energy in Manufacturing

Energy sectors like solar and wind are gaining traction in India. When asked how does Mazak address these industries, Yamazaki shared “While the solar and wind segments

do not require specialized machinery, our solutions are versatile. For instance, our laser cutting machines are ideal for manufacturing solar panel components. We continue to support customers in these sectors with adaptable, high-precision tools.”

Mazak's commitment extends beyond machinery. The company actively collaborates with manufacturers to develop components for renewable energy systems, contributing to India's sustainability goals.

IMTEX: A Platform for Growth

Yamazaki has been attending IMTEX for nearly 20 years, and he comments that the scale has grown significantly. “But it's not just about size—the increasing engagement from Indian customers is remarkable. IMTEX 2025 promises to be our busiest yet, and we are fully prepared to showcase our Indian-made machines alongside innovations from Japan and Singapore.” Mazak's exhibits at IMTEX 2025 focus on creating a hands-on experience for visitors. “We do not just display machines; we demonstrate cutting-edge technologies and processes to show customers what's possible with Mazak,” Yamazaki added.

Yamazaki Mazak India Pvt Ltd
www.mazak.com
Hall & Stall: 4/B-101



UNLOCK PRECISION IN ELECTRONICS MANUFACTURING WITH ANCA CNC MACHINES



Download a free whitepaper on the latest trends, opportunities, and strategies shaping India's thriving electronics sector



Visit us at IMTEX 2025
Hall 4, Stand B110



Experience the Value in our Machines & Solutions

Hall - 5, Stall - A 108

HEAVY DUTY Series



- JV 150** Vertical Machining Center
- Stroke: (X,Y,Z) - 1550 mm x 760 mm x 760 mm
 - Table Size - 1700 x 700 mm
 - Max. Load on table - 1300 kg
 - Spindle speed - 6000 rpm
 - Spindle taper - BT 50
 - No. of Tools - 24 Nos



LTV 40 Plus Vertical Turning Center

- Max. Turning Length - 750 mm
- Max. Turning Dia - 640 mm
- A2-11 spindle nose
- Maximum swing over bed diameter 800 mm
- 12 station Hydraulic Turret
- Enhanced chip collection and flow management



INDIA'S FINEST RANGE OF CNC MACHINES

TURNING MILLING TURNMILL



www.lmwcnc.com

IMTMA INITIATIVE

Catalyzing Industry-Academia Partnerships



It is well-recognized that industry-academia collaboration is crucial for developing innovative and high-quality products. Building on this premise, IMTEX 2025, like every year, set up a dedicated 'i2 Academia pavilion' where students from

14 engineering colleges have displayed their innovative engineering projects. Commenting on their project, V Dhinakaran, Dean Research & Development, Chennai Institute of Technology, said, "Since 'Make in India'

has been our country's focus, we have developed an innovative project on the Gas Bottles used in the aerospace sector. The gas bottles are welded by CMT welding process. We have developed a new welding method called Friction Stir Welding (FSW), along with a company called Micro Concept Tools. This collaboration was developed two years back through the i2 Academia platform." Explaining their engineering work on advanced energy management P Surya Bharath, Assistant Professor, Potti Sriramulu Chalavadi Mallikarjuna Rao College of Engineering &

Technology, Andhra Pradesh, said, "IMTEX presents an ideal platform to bridge the gap between the academia and industry and for students to gain exposure to the industry and other colleges." Commending IMTMA's initiative, Assistant Professor Mani Pandi AS from Department of Mechanical Engineering, Tagore Engineering College, Chennai, said, "IMTEX 2025 has created a remarkable opportunity for students to step out of the four walls of their college and gain insight into the technological trends of the ever-evolving industry." **SD**

INSPIRING INNOVATION

JAGRUTI - IMTMA Youth Programme For a Brighter Future

The 'JAGRUTI - IMTMA Youth Programme' is an initiative by Indian Machine Tool Manufacturers' Association (IMTMA) to aid engineering students stay abreast of the latest developments and trends in the manufacturing sector. Held during IMTEX 2025, the program is supported by UDAAN members and serves as a platform to ignite interest in students for the machine tool and manufacturing industries. Under this initiative, selected engineering students from short-listed institutions are given a unique opportunity to gain insight into the industry's cutting edge.



IMTMA ensures a seamless and enriching experience for the participants by covering all expenses, including:

- A comprehensive guided tour of the show.
- An in-depth session at IMTMA's Technology Centre.

- To-and-fro train travel from their respective cities to Bengaluru.
- Accommodation and related expenses during their stay, excluding personal expenses.

Post-program, students are required to submit two assignments based on their observations during IMTEX and Tooltech,

which are reviewed by IMTMA and their nominating institutions.

IMTEX 2025 Highlights

This year's program welcomed 29 students from 13 engineering institutions across India: Region-wise participation was comprised of 11 students, 16 students from South, and 2 students from East. Branch-wise participation included 22 students from Mechanical Engineering, 2 from Manufacturing and Robotics, and 3 from Electrical. Year-wise participation featured 24 from the Third Year, 3 from the Final Year, and 2 from the First-Year Masters. **SD**

SEMINAR

JMTBA Seminar on Export Controls for Japanese Machine Tools



Japan Machine Tool Builders' Association (JMTBA), yesterday, on January 27, 2025 conducted a seminar and live webinar on 'Export Controls for Japanese Machine Tools'. The event was held at the

IMTMA Technology Centre and also streamed online via Microsoft Teams. Presented by Kazuo Okada, Executive Member, Export Control Committee, JMTBA, the seminar provided participants with an overview of

security export regulations and compliance requirements for Japanese machine tools. Key topics included the importance of export controls, compliance procedures, and steps to manage machine tools before and after delivery from Japan. Designed exclusively for distributors of Japanese machine tools in India, the event emphasized the role of export controls in preventing the misuse of sensitive technologies. "Export Control" means the controlled transfer of technologies or exportation of goods

and software in order to prevent transfer that can be potentially diverted to weapons of mass destruction or military use. In particular, machine tools are sensitive goods in security export control," said Okada. "Many developed countries have strict regulations on machine tools exports, based on international regime. This seminar will provide you an overview of the regulations regarding security export control for Japanese machine tools and how to comply with them," he added. **SD**

ADVANCING MANUFACTURING

Precision Rotary Tables for Future

Please visit us at **Stall No. A102, Hall No. H1A**

Experience with us **New Technologies & Innovations**

- Tilting Rotary Table
- Roller Cam RT
- DDR Cartflower Table
- 4th Axis Direct Drive

Introducing **Advanced Automation & IOT Enhanced Rotary Tables**



Contact
080-40744712
info@ucamind.com
www.ucamind.com

Head Office
A-11/12, 1st Stage, 1st Cross,
Peenya Industrial Area,
Bangalore - 560058

ACCOMPLISHMENTS

Grind Master Machines Celebrates Significant Milestones at IMTEX 2025



Source: Magic Wand Media

Grind Master Machines celebrated two of its milestones – the 40th anniversary of Grind Master Machines and the unveiling of the book 'Garage to Global' by Sameer

Kelkar, CEO, Grind Master – along with the machine tool fraternity present at the exhibition, including IMTMA members, the company's suppliers and customers. Mohini Kelkar, Co-founder and Director, Grind Master Machines, said, "It is with immense joy and

pride that I stand here today as we gather to celebrate these remarkable milestones of Grind Master Machines, a company that has been a symbol of innovation, perseverance, and excellence for four decades. As we celebrate 40 years of success, we also look

ahead to new horizons with fresh ideas, young leadership, and a renewed vision." "Sameer, my son, has a different vision not only for Grind Master but also for the entire Machine Tool fraternity. He has written this book not only on the journey of Grind Master, but all of our journeys. The book will leave a lasting impression since we all have gone from 'Garage to Global'", she added. The book 'Garage to Global' is a corporate biography with a difference. An honestly narrated story of a journey that has surmounted numerous challenges and clocked many milestones on the way. The event formally began with a 'Vriksha Pooja', watering of a mahogany sapling at the hands of industry veterans. The gathering also took a moment to remember Late Mr Shailesh Sheth, guide and mentor to Grind Master and many others in the machine tools industry. **SD**

WEISS
An Innometrics Business

Rajamane & Hegde Services Pvt Ltd

Rajamane
SINCE 1975

2SP2 Motorspindles



2SP2 the new middle-class standard

The new 2SP2 asynchronous milling spindle series is characterized by robustness and performance. Its compact dimensions meet the necessary requirements to keep the space requirement in the machine as low as possible. The option with or without external cooling jacket offers the machine builder flexibility in designing the connection of the spindle to the Z-slide.

Here, the new spindle series with an outer diameter of 170 mm already achieves a nominal torque of 45 Nm. For applications requiring more spindle torque, a variant with an outer diameter of 210 mm is available.

The spindle has been designed with a slim diameter and open cooling jacket but is also optionally available with a closed cooling jacket.

The robust bearing system ensures speeds of up to 20,000 rpm with lifetime grease lubrication. For speeds of up to 24,000 rpm, a version with air-oil lubricated bearings is also available. The specially developed asynchronous motor is equipped with loss-optimized profile rods to keep the rotor losses as low as possible. In this way, the spindle ensures low heat-up and reduced growth at the tool interface, even at maximum speeds.

For more information, please ask for spindle catalogue.

India's only authorised service partner for Weiss spindles

YCM

S&T ENGINEERS

N X V S E R I E S

PRECISION | POWER | PROFIT

The New Evolution in Machining

When uncompromising accuracy meets relentless speed, the result is pure machining brilliance. Experience world-class performance that doesn't just meet your expectations – it exceeds them, all while maintaining remarkable cost efficiency.



FEATURES

1. Rapid Feed Rate:
NXV600A → 48/48/48 m/min
NXV1020A → 48/48/32 m/min

2. Auto Tool Change Time:
NXV → 1.8 sec
NXV1680B → 4.2 sec

3. Max. Spindle Power:
NXV1380A /
NXV1680A → 30 kW

4. Acceleration Enhancement:
NXV600A → 1g / 1g / 0.76g
NXV1020A → 0.9g / 0.7g / 0.8g

5. Tool Magazine Capacity:
NXV1020A / AM → Max. 40T
NXV1270A / NXV1380A
NXV1680A → Max. 60T (opt.)

EXCLUSIVE DISTRIBUTOR
★INDIA★

1000+
INSTALLATIONS
Across India

Visit Our Stall : Hall: 1A | Stall No: B101

S&T ENGINEERS (P) LTD.

+91-422-2590810 +91 73059 92830 info@stengineers.com www.stengineers.com

MAKING TECHNOLOGY AFFORDABLE

25+
YEARS
S&T GROUP
SINCE 1996



TOOL HOLDERS AND ROTARY TABLES

Ushering in a New Era of Automation



“At IMTEX 2025, we see an invaluable opportunity to showcase our innovative solutions and connect with customers across industries,” shares Vinay Javali, Head of Sales, Eppinger Tooling Asia Pvt Ltd.

Eppinger is displaying its full range of products from its portfolio, including:

- Tool Holders: Static and Live Tool Holders for turn-mill machines, as well as new Tool Holders for machining centers, such as

Collet Chucks, Shrink Fit Holders, Hydraulic Holders, Milling Chucks, Face Mill Arbors, PSC Holders, and Tapping Tools.

- Rotary Tables: High-performance CNC Rotary Tables with integrated angle sensors, universal mounting design, optimal gear ratios, and multi-disc clamping for enhanced precision and productivity.
- Gears and Gearboxes: Planetary and cycloidal gearboxes,

along with loose gears, designed for industries such as automation, robotics, process engineering, and more.

Innovations Tailored for India

Eppinger’s Live Tool Holders are well-established in the Indian market and remain the first choice for several OEMs and end-users. Javali highlights the company’s focus on durability and efficiency: “Our patented Preci-Flex® adapter system and Compensation Clutch technology enhance tool performance, minimize vibration, and ensure better cutting results.” The company also foresees significant potential for its Gear and Gearbox products, which combine high precision, energy efficiency, and smooth operation to meet the growing demands of the Indian manufacturing sector.

One of the most exciting developments is Eppinger’s QUICK LOCK system, an automated tool holder mounting solution for turn-mill machines.



Source: Eppinger Tooling Asia Pvt Ltd

» IMTEX is an essential platform for us to connect with our existing and potential customers under one roof. It allows us to showcase our innovative products and solutions, exchange ideas, and gather valuable feedback that drives our strategy for new product development.«

Vinay Javali
Head of Sales
Eppinger Tooling Asia Pvt Ltd

“This innovation eliminates manual intervention, setting new standards for efficiency in tool-changing technology,” explains Javali. SD

Eppinger Tooling Asia Pvt Ltd
www.eppinger.de
Hall & Stall: 3A/B-111

PMT MACHINES LIMITED

PUNE & HALOL

CNC Turning Center 5000 ABC

CNC Gear Hobbing

CNC Vertical Turning

CNC Cylindrical Grinding

CNC Internal Grinding

Surface Grinding

Automat

YOU ARE INVITED TO VISIT THE EXHIBITION

HALL NO - 2A STALL NO - B110

23-29 January, 2025 | BIEC - Bangalore

www.pmtmachines.com

UNITED FOR YOUR SUCCESS

AT UNITED GRINDING, EXPECT UNCOMMON STRENGTH THAT DRIVES YOU FORWARD.

Hall 4,
Booth A 115

A core tenet for everything we do at UNITED GRINDING India: when our customers succeed, we do too.

It’s why we offer innovative, world-class precision grinding machines with standards and architecture that goes back centuries. A dedicated applications and engineering team with knowledge to share and projects to support. And an always-there Customer Care team for everything you need after the sale. We are in it with you until the job is done, and we’ll be there when the next one starts. We are united for your success.



ULTRA PROBING SYSTEM

Ultra-Wideband Transforms Precision



Source: Marposs

Known for showcasing groundbreaking innovations, Marposs India Pvt Ltd highlights its technological advancements, displaying 30 products that align with industry demands for efficiency and sustainability, especially for the metal-cutting industry.

Raising the Bar

"IMTEX 2025 is a key platform for us to demonstrate our technological advancements with new segment technology, such as smart sensors, automation, precision monitoring

systems, electric vehicles (EVs), semiconductor, and 'Make in India' Initiative," says Luca Matteucci, Managing Director, Marposs India. "It provides an opportunity to connect with industry leaders, strengthen partnerships, and showcase our commitment to advancing the future of manufacturing."

Tools That Hit the Mark

Key offerings include solutions for precision measurement, tool life optimization, and energy-efficient machining. "These technologies aim

to enhance manufacturing efficiency, reduce waste, and support sustainability in the metal-cutting industry," stresses Matteucci.

Ultra-Wideband: A Game Changer

Marposs' Ultra Probing System with Ultra-Wideband technology represents a breakthrough for the machine tool industry. "Thanks to this technology, Marposs can place itself at a higher level of transmission than the standard, offering a new solution unmatched in terms of performance and reliability," Matteucci explains.

Smart Moves, Smarter Manufacturing

Marposs' solutions are driving the digital transformation of machine shops by integrating smart sensors, real-time monitoring, and advanced data analytics. "These technologies—enable predictive maintenance, optimize machining processes, and improve precision, aligning with the principles of Industry 4.0."



Source: Marposs

» Marposs' Ultra Probing System, a new revolutionary touch probing solution for the machine tool industry powered by Ultra-Wideband technology, sets a higher standard of transmission, delivering unmatched performance and reliability.«

Luca Matteucci
Managing Director
Marposs India Pvt Ltd

"This integration—he continues—enables adaptive control, where robots and automated systems make adjustments based on live feedback, optimizing production processes in smart manufacturing environments." **SD**

Marposs India Pvt Ltd
www.marposs.com/eng/
Hall Stall: 3A/B102

Visit us at Hall 3A, Stall B111

High Speed High Precision CNC Rotary Tables

4th Axis redefined

- Integrated angle sensor
- Positioning accuracy: ±5"
- High clamping torque
- Universal mounting

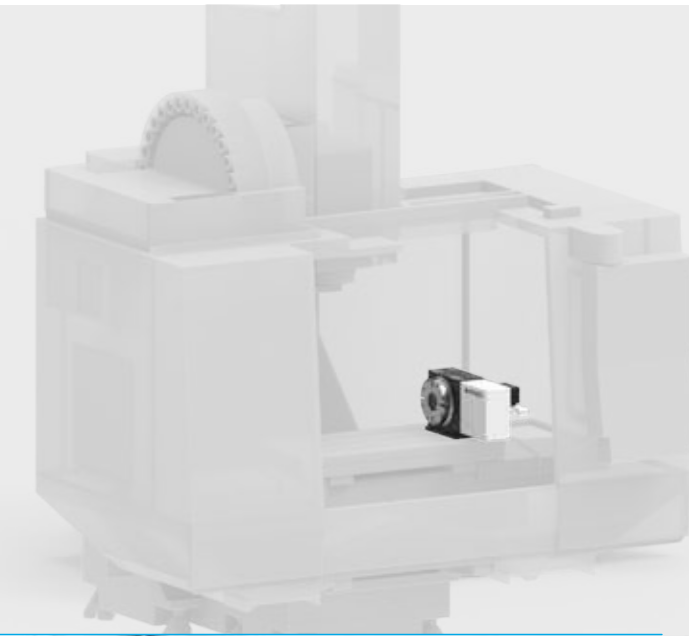
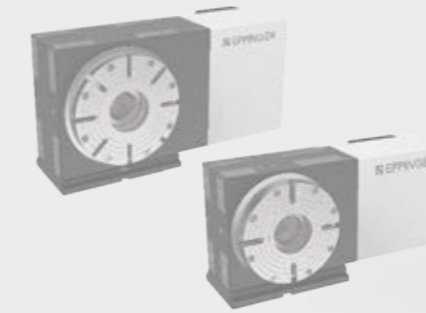

Your Partner For All Tool Holding Solutions

Up to fully automated tool change on lathes

- 1 QUICKLOCKBMT® tooling system
- 2 Tool holder HSK/SK/PSC
- 3 Automation for tool holder & work piece
- 4 Your work piece

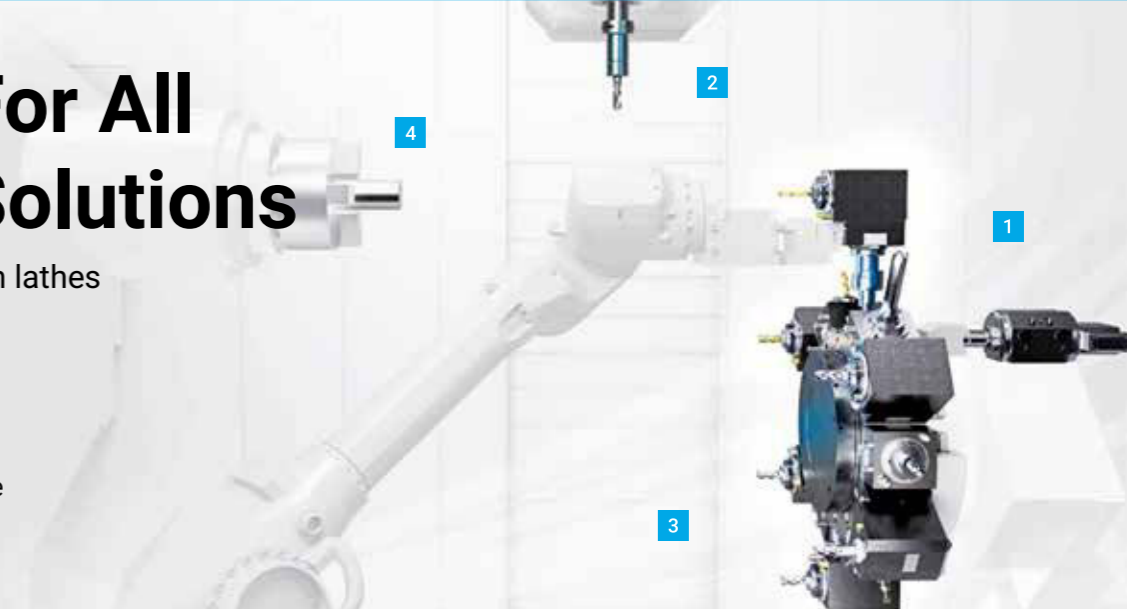

Precision Gear Units

For all machine tools

- 1 Tool disk / magazine
- 2 Tool changer
- 3 Material handling solutions

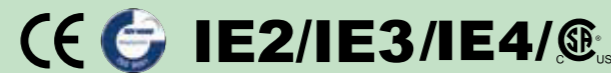

Delivering Solutions



- ▶ **Machining**
Flooding | Circulating | Grinding | Chip Conveyor | Filtration
- ▶ **High Pressure Cooling**
Through Tool | Washing | Filtration
- ▶ **Oil Skimming**
Belt | Disc
- ▶ **Refrigeration / Temperature Control**
Printing | Packing | Welding | Mold Temperature
- ▶ **Media**
Water | Coolant | Chemicals | Oil | Ink | Varnish | Washing Solution
- ▶ **Pump with BLDC Motor**



FOR ENERGY INDUSTRY

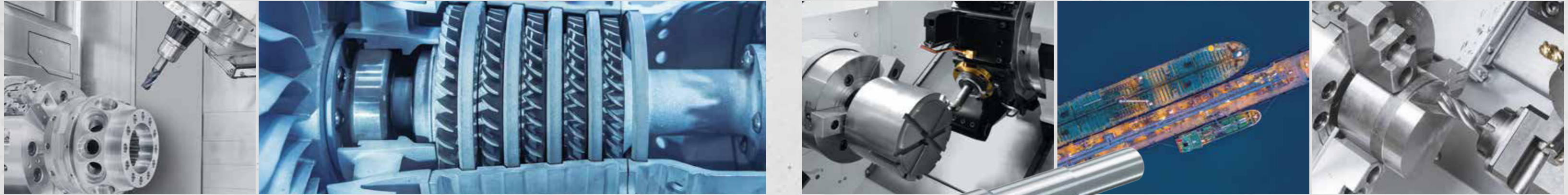

Multi-Tasking Machine

INTEGREX i-200H S

Multi-Tasking Machines with AI, digital twin technology and automation transform manufacturing sites

- The flat design of the machine body front greatly improves accessibility and linkage with automation systems
- Power increased spindle and high rigidity machine structure

CNC Turning Center

QTE-300 MY SG

High-speed, high-accuracy, space-saving CNC turning centers

- Built-in motor for high cutting capacity
- Support of a wide range of specifications allows selection of models per production
- A variety of optional automation equipment can be chosen to increase productivity

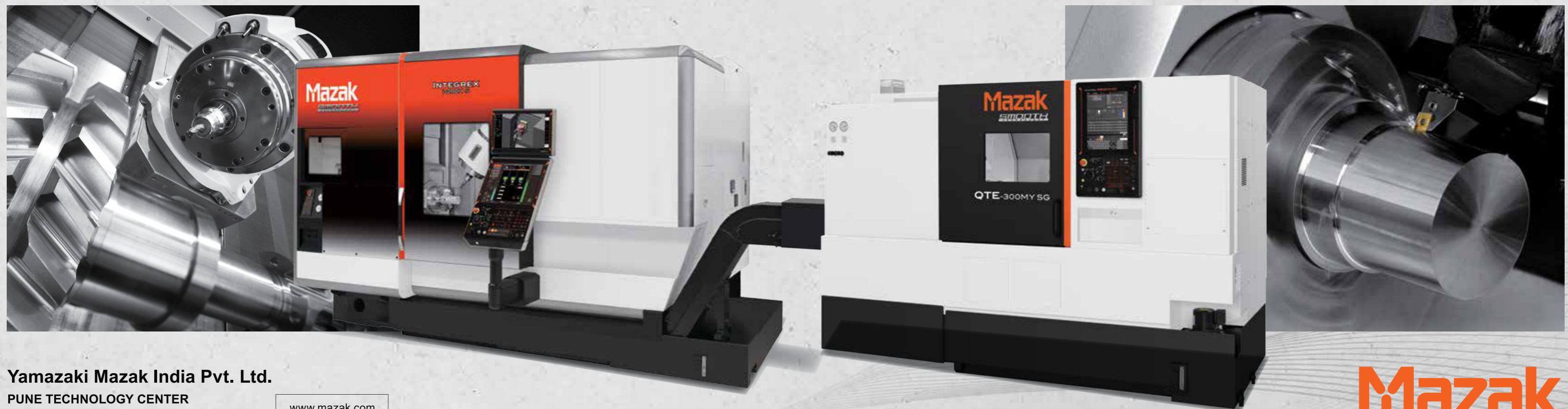

Yamazaki Mazak India Pvt. Ltd.
PUNE TECHNOLOGY CENTER
115, Pune Nagar Road, Sanaswadi, Pune. 412208.

www.mazak.com



VERTICAL TURNING MACHINES

PMT's Machines for Heavy-Duty Machining Applications

The PMT Vertical Turning machines offer a robust mechanical structure, ensuring stability and flexibility for machining processes of several types of large parts. These machines can be customized according to the application for which they are intended for. PMT's CNC double-column Vertical Lathes accommodate bigger and heavier parts and are capable of taking heavier cuts which reduces cycle times. Final finishing on the job can be done to control surface finish and maintain close tolerances.

Source: PMT Machines Ltd



PMT Machines Ltd
www.pmtmachines.com
Hall & Stall: 2A/B-110

TPMT VTL machines offers unparalleled heavy-duty machining applications along with precision and speed. They are engineered for industries requiring robust performance and ensuring superior efficiency and reliability for large components. Table sizes start ranging from a minimum of 1.2 m to a maximum of 3.0 m, with turning diameters ranging from 1600 mm to 3500 mm,

a table drive power of up to 100 kW. Ram is available in two sizes 250 x 250 or 300 x 300 mm. The machine's table load capacity of is 15 tonne. The machines are also optionally equipped with cutting-edge CNC controls, live tooling, automated tool

changers and also a W-axis, ensuring seamless operation and maximum productivity. These machines are ideal for applications in industries, including Energy, Aerospace, Heavy Automobiles, and Defence.

SD

DELEGATE SPEAK

IMTEX Helps Us Stay Informed



Source: Magic Wand Media

"I am a regular participant in IMTEX since 1976, and IMTEX 2025 is exceptionally well organized. With around 1,250 stalls this year, it's truly a remarkable achievement. I am especially pleased to see strong representation from domestic machine tool manufacturers, showcasing numerous innovative products. IMTEX 2025 serves as an invaluable platform for this purpose. I wish for an unprecedented turnout at this year's event."

R Chandra Shekar
National President
Member - Board of Governors
Indian Institute of Plant Engineers
Engineering Council of India (ECI)



Rajamane & Hegde Services Pvt Ltd



Hybridspindle



More than only an alternative for indirect spindle solutions

The hybrid spindle is an impressive development - the combination of the master spindle motor and the spindle functionality results in a high-quality milling spindle.

The design includes all necessary spindle functionality, maximum speed up to 24,000 rpm and high accuracy because of direct driven technology. The Hybrid Spindle gives to machine builders the possibility to improve the performance of machines originally built with indirect spindle solution.

For more information, please ask for the spindle catalogue.

India's only authorised service partner for Weiss spindles

Mastercam®

WORLD'S #1 CAM SOFTWARE



Visit us at Booth A-102, Hall 1B



MILL



MULTIAXIS



LATHE



MILL-TURN



WIRE



ROUTER



DESIGN



ADDITIVE

GRINDING SOLUTIONS

Pursuing Perfection



Source: Palmary Machinery Co., Ltd.

For Palmary Machinery Co., Ltd, IMTEX 2025 is not just a trade show – it's a platform to connect with global customers and showcase cutting-edge technology. "India is a leading market for the global engineering industry, with rapid advancements in technology. It's an excellent opportunity to showcase our solutions and exchange innovative ideas," says Tiger Wang, General Manager, Palmary Machinery Co., Ltd.

Highlighting Cutting-Edge Grinding Solutions

Palmary features three key machines at IMTEX 2025. The CNC Centerless Grinder FCL-18-3, designed for high-speed grinding, is ideal for applications requiring stable performance and multi-axes selection. "This machine is perfect for thrufeed and multi-step grinding, offering high precision and automation," adds Wang. The TG-5 CNC 5-Axes Tool Grinder boasts flexibility and precision,

equipped with the NUM Flexium+68 controller and NUMROTOplus® software. Wang explains, "It's an efficient and economical solution for CNC tool grinding, providing unparalleled precision." Another standout, the T-1012 T Series 2-Axis NC Cylindrical Grinder, is designed for multi-step grinding in one cycle, optimizing efficiency and precision.

Focusing on Indian Market Needs

Palmary's solutions are tailored to the Indian market, offering both advanced automation and economical options. "Our FCL series is ideal for customers looking for flexibility in size and cutting precision," says Wang. "The OCA-H series, with its wide wheel width and heavy-duty base, reduces cycle time and improves grinding performance."

Strong Service Network

Palmary is committed to providing excellent after-sales service in



Source: Palmary Machinery Co., Ltd.

» India is a leading market for the global engineering industry, with rapid advancements in technology. It's an excellent opportunity to showcase our solutions and exchange innovative ideas. «

Tiger Wang
General Manager
Palmary Machinery Co., Ltd

India. "We have built strong relationships with local partners, ensuring mutual growth through regular training, sharing technological advancements, and a dedicated service team for swift, immediate assistance," shares Wang. **SD**

Palmary Machinery Co., Ltd
www.palmary.com
Hall & Stall: 1B/B-111



Source: Chennai Metco Pvt Ltd

ASSESSING WELDMENTS

Chennai Metco's Weld Validation Module

Welding as a process is now employed everywhere in fabrication and construction. The stability of weld and its ability to stand the service conditions are now a major concern for automobile manufacturers and other system builders.

The American Society of Mechanical Engineers (ASME) has now mandated microstructural weld validation as a compulsory method for assessing weldments. This process involves sectioning the weld zone and measuring key parameters to ensure compliance with established standards, becoming a routine practice in the industry.

Chennai Metco offers comprehensive, end-to-end solutions for weld validations, encompassing sectioning, grinding, polishing, imaging, measuring, and standards compliance.

Chennai Metco Pvt Ltd | www.chennaietco.com | Hall & Stall: 1/A-101



Aerial view of TMTP

TUMAKURU MACHINE TOOL PARK

ATTRACTIVELY PRICED READY TO BUILD INDUSTRIAL PLOTS
VASANTHANARASAPURA INDUSTRIAL AREA - PHASE III

Machine Tools
All types

Parts Accessories
attachments
Sub-Systems

Cutting Tools
Tooling

Dies &
Moulds

Electrical &
Electronics 14.0

Automation

Service
Providers

INDUSTRIAL PLOTS | LOGISTICS | SOPHISTICATED AMENITIES | COMMON FACILITIES

For queries please contact Mr. Manjunath.L Chief Marketing Officer, TMTP.
Ph: +91 9845525245 Email: cmo@tmtp.in

Government of India
Ministry of Heavy Industries

Government of Karnataka
Karnataka Industrial Area
Development Board (KIADB)

Tumakuru Machine Tool
Park (TMTP)

www.tmp.in

CNC PROBES

Probing Deeper with Manleo Designs

“IMTEX has always been a prominent platform for the machine tool industry in India.

The show is a much-anticipated one even at a global level now,” says Abhijith Bhat Narya, Managing Director, Manleo Designs Pvt Ltd. Building on its successful participation in IMTEX 2023, Manleo Designs has expanded its presence significantly. “Given our fantastic experience during IMTEX 23, we have booked a stall 2.5 times bigger than our previous one,” Narya shares. He highlights the event's role in launching new products, meeting existing and prospective customers, engaging with machine tool builders (MTBs), and exploring collaborations to take Manleo global.

Innovations on Display

At IMTEX 2025, Manleo Designs is showcasing two key machines – a Vertical Machining Center (VMC) and a CNC Turning—with all products integrated into these systems. In addition to the



Source: Magic Wand Media

company's existing star products, the work probe and tool probe, Manleo Designs plans to introduce upgraded versions with enhanced automation and technologies such as laser and wireless communication. It also aims to launch highly affordable solutions tailored to automotive and mass-production customers. The highlight of Manleo Designs' display is the 3D Datum Finder. "It

doubles up like a CMM-type of probe with its unique feature where the in-machine inspection can be completed without any need for additional software purchase. This saves rework and rejection by over 75 percent," he shares. During IMTEX 2025, Manleo Designs has unveiled an automatic version with integrated inspection software, priced competitively at INR 1.5 lakh—significantly more

Manleo Designs Pvt Ltd
www.manleo.com
Hall & Stall: 6/B-102

affordable than current alternatives costing 4 to 8 times more. The show also made for an ideal platform for the company to formally join forces with Rakesh Aggarwal's Lazer Technologies. This partnership unites technology and business expertise, combining innovation with dynamic leadership. Together, they aim to revolutionize precision engineering, strengthening India's position in the global CNC tooling industry.

Future-Ready Solutions

Manleo Designs's product range includes automatic probes and tool setters for Vertical Machine Centers and Horizontal Machining Centers, alongside prototypes designed for CNC lathes, VTLs, Grinding, and EDM machines. "We recommend a 3:1 ratio, i.e., for every three machines, one probe can suffice. This makes it a light-on-pocket investment for companies while allowing them to extend probing across their shop floor," Narya explains. **SD**

HORIZONTAL MACHINING CENTERS

JHF 400 – Horizontal Machining Center

The JHF 400 from LMW Ltd is a High-Speed Horizontal Machining Center that combines speed and precision with a stroke of 600 mm x 500 mm x 500 mm, an automatic pallet changer with a size of 400 mm x 400 mm, and a high-speed spindle operating at 12,000 rpm. It includes a twin arm type ATC with 30 tools and a rapid traverse rate of 48 m/min. The machine is ideal for industries like Pump & Valve, Automobile, Oil & Gas, Agri & Earth Movers, and General Engineering. **SD**

LMW Ltd
www.lmwnc.com
Hall & Stall: 5/A-108



Source: LMW Ltd

Would you like to be crowned a Productivity Champion ?

... Share your success stories on PRODUCTIVITY | TECHNOLOGY | INNOVATION



IMTMA - ACE MICROMATIC
Productivity Championship
Awards 2025

Win Cash Awards upto

₹ 10,00,000

@
National Productivity Summit 2025
November 2025, Ahmedabad

AWARDS SPONSOR



No Entry Fee !

Multiple Entries are Welcome !

Rush your entries by 5 April 2025

Special streams Micro and Small Enterprises | Non-Automotive Industry | Automotive and Auto Component Industry

For more details, please log on to: www.productivity.imtma.in
or call Madan on: +91 7899437625 | E: madan@imtma.in

Organised by: Indian Machine Tool Manufacturers' Association
www.imtma.in

TOOL CLAMPING SOLUTIONS

Clamping Down with Swiss Tools

“IMTEX 2025 is an exceptional platform for us to showcase our industry-leading innovations,” shares Makarand Dande, Managing Director, REGO-FIX India Pvt Ltd. At this year’s event, the company spotlights its cutting-edge solutions, including the ForceMaster Adapter, toolVibe, powRgrip® system, reCool® Retrofit System, and the sustainable Blue Eco technology.

Key Highlights at IMTEX 2025

- **powRgrip® Tool Clamping System:** Known for its unparalleled clamping force and precision, the powRgrip® system ensures a total system runout (TIR) of $\leq 3 \mu\text{m}$ at $3 \times D$, making it ideal for high-speed machining. “Its superior vibration dampening and quick tool changes enhance productivity and tool life,” emphasizes Dande.
- **ForceMaster Adapter:** A digital pull-force tester that seamlessly connects to smartphones and tablets for remote monitoring and accurate spindle force measurement, ensuring process safety.
- **toolVibe:** This advanced sensory toolholder features accelerometers for real-time vibration monitoring, optimi-



Source: Rego-Fix

zing machining performance and improving setup accuracy.

- **reCool® Retrofit System:** Designed for CNC turning and Swiss automatic machines, it converts external cooling to internal cooling in as little as two minutes. This system significantly enhances cooling efficiency, tool life, surface finishes, and overall productivity

REGO-FIX India Pvt Ltd
www.rego-fix.com
Hall & Stall: 3A/B-108

while operating with speeds up to 12,000 rpm and pressures of up to 100 bar.

Driving Value Across Industries

Every product from the company is designed to add value to machining across sectors like automotive, aerospace, medical, and die & mold manufacturing. “As a trendsetter in tool clamping, our solutions cater to the dynamic needs of global and Indian industries, ensuring superior productivity and precision,” adds Dande.

Engaging with Key Stakeholders

REGO-FIX anticipates a vibrant turnout from technical institutes and industries at IMTEX 2025. “We are eager to connect with stakeholders who value innovation and reliability in machining,” Dande concludes. **SD**

5-AXIS MACHINING CENTERS

Jyoti CNC's Versatile K3X8 FIVE

In order to provide simultaneous 5-axis operations and a seamless transition from roughing to finishing across a wide range of complex, high-precision applications, the KX Five Series integrates a high-speed machining (HSM) architecture. For all machining processes, its fixed portal structure ensures an ideal combination between dynamic performance and exceptional accuracy, leading to superb surface quality. The KX Five Series' high-performance electro-spindle guarantees quick metal removal rates, increasing machining efficiency. The rotary table's 55° inclination capacity, made possible by its TRIM technology design, allows for negative angles that improve operational flexibility.

With a work surface of $\phi 500 \text{ mm}$ and a rotating speed of up to 50 rpm, the table may be precisely tilted from +30° to -180°, providing flexibility for intricate machining needs. Several variants with several pallet options and an automatic tool changer (ATC) are available in the KX Five Series, which greatly increases production.

This series, which was created especially to satisfy the requirements of high-integrity mechanical parts, complex aerospace components, and injection molds, ensures remarkable efficiency and versatility in a wide range of precision machining applications. **SD**

Jyoti CNC Automation Ltd
www.jyoti.co.in
Hall & Stall: 5/A-122



Source: Jyoti CNC Automation Ltd

TWIN SPINDLE ADVANCED CNC CHUCKER

MW120EXG for High-Precision Turning

Muratec's (Murata Machinery, Ltd) workhorse, the MW120 Series, has evolved to a higher level. The advanced MW120EX twin-spindle chucker delivers high-precision turning and features a high-speed gantry that is lightweight yet offers excellent rigidity due to its material design. It is exceptionally effective for interrupted cutting conditions, thanks to the box guideways in the X-axis, and provides an outstanding surface finish. It is highly suitable for hard part turning applications, with a CFRP loader available as an option. Some of the most suitable applications include automotive components

such as inner races, differential pinions and gears, soft and hard turning, CVJ inner races, AC compressor parts, rotor vanes, as well as transmission and engine components. This machine is available with a 6" or 8" chuck capacity and comes standard with an 8-station turret. A 12-station turret and twin gantry are available as optional features. The MW120EX is equipped with a 7.5 kW spindle motor as standard, with an optional 11 kW motor available. Spindle bearing accuracies have been further enhanced to deliver better roundness, exceptional surface finishes, and extended tool life. **SD**

Source: Meiban Engineering Technologies Pvt Ltd



Meiban Engineering Technologies Pvt Ltd
www.meibanengg.com
Hall & Stall: 5/B-105

5-AXIS UNIVERSAL MACHINES

The G350 from GROB

The G350, one of GROB's proven 5-axis universal machines, is known for its flexibility and efficiency in the machining industry. It impresses with its compact design. Thanks to the intelligent arrangement of the tool magazine, the machine width has been reduced from 2,450 mm to a compact 2,000 mm without compromising performance. This allows companies to save valuable space in the production hall and at the same time, benefit from more tool capacity and greater machining efficiency.

Thanks to the double disk-type tool magazine, it is possible to work with tool lengths of up to 550 mm,



Source: GROB Machine Tools India Pvt Ltd

which significantly increases flexibility in production. The tool capacity is 60 places, in the double disk-type tool magazine even 117 places. Another strength of the G350 is its high dynamics and short secondary and chip-to-chip times, which further increases the efficiency of the task. The excellent accessibility and visibility into the work area also make the machine particularly user-friendly. All these features make the G350 the ideal solution for a wide range of companies that expect maximum precision and speed in production.

With its 5-axis universal concept, the G350 is ideal for a wide range of industries - from aerospace, mechanical engineering and automotive to medical technology. Thanks to its modular design and the use of standard components, GROB also guarantees maximum process reliability, cost-effectiveness, and durability. **SD**

GROB Machine Tools India Pvt Ltd
www.grobgroup.com
Hall & Stall: 4/C-116



Source: Magic Wand Media

Insights on Omnibus Technical Regulations (OTR) at IMTEX 2025

The Omnibus Technical Regulations (OTR) for Machinery and Electrical Equipment Safety-2024 is a pioneering framework in India, aimed at enhancing manufacturing sector capabilities and ensuring safer workplaces. The regulation, which focuses on machinery and electrical equipment safety, was notified on August 28, 2024, and will come into effect on August 28, 2025.

The machine tool industry is keen to explore the implications of this regulation. To address the industry's queries, under the aegis of the Ministry of Heavy Industries (MHI), IMTEX 2025 organized an awareness session on January 27, 2025. In his welcome address, Rajendra S Rajamane, President, IMTMA,

emphasized, “We have received numerous email requests from our members seeking clarification about this regulation. What are the various aspects of the OTR? The ministry is firm on the implementation of this order and its deadline. Therefore, we must understand it thoroughly.” During the session, Dr Nagahanumaiah, Director, Central Manufacturing Technology Institute (CMTI), delivered a special address on OTR. Following this, Mohit Janohiya, Scientist 'D' and Joint Director, Central Marks Department - I, Bureau of Indian Standards (Gol), gave a detailed presentation on the subject. After an engaging Q&A session, Mohini Milind Kelkar, Vice President of IMTMA, extended the vote of thanks to all attendees. **SD**

METALWORKING FLUIDS

Helping Metals Perform Better



Source: Zavenir Daubert India Pvt Ltd

At IMTEX 2025, Zavenir Daubert is showcasing its comprehensive CUT-CLEAN-PROTECT-PACK solutions, offering end-to-end support to the manufacturing industry. The booth features X-Series Metalworking Fluids, a range of sustainable solutions. Alongside the renowned NOX RUST products, a leading brand in the Indian market for rust-preventive oils and waxes for over three decades, Daubert VCI Packing Solutions is also being displayed.

Solutions for Indian Manufacturing

“Zavenir Daubert's motto, 'Helping Metals Perform Better', reflects our commitment to meeting the specific needs of the Indian metal processing industry,” shares Kapur. The company's product portfolio, which includes Metal Cutting and Cleaning solutions, Rust Preventive Fluids, and Packaging Materials, is carefully crafted to offer both cost-effectiveness and exceptional quality.

Cutting-Edge VCI Technology.

“As you might be aware, Volatile Corrosion Inhibitor (VCI) technology was invented by George Daubert, the founder of the Daubert company,” Vikas Kapur, Chief Business Officer, Zavenir Daubert India Pvt Ltd shares with pride. Key benefits of the VCI technology include an innovative triple-layer technology that improves film strength and controls moisture, combined with eco-friendly VCI paper crafted from virgin kraft material free of harmful chemicals. This guarantees corrosion protection for metal components during storage and transit.

The NOX RUST Advantage

For customers, the NOX RUST range is synonymous with 'no rust,' offering peace of mind through uniform protective films that shield components from atmospheric corrosion. With high flash points, reduced oil consumption, and non-tacky protective layers, this range ensures superior performance in industrial applications. **SD**



Source: Zavenir Daubert India Pvt Ltd

“Being one of the biggest exhibitions for the Manufacturing sector, IMTEX 2025 brings together major manufacturing firms under one platform. It gives us an excellent opportunity to interact with manufacturers, understand their requirements, and offer our innovative and sustainable solutions.”

Vikas Kapur
Chief Business Officer
Zavenir Daubert India Pvt Ltd

Expertise Across Sectors

While Zavenir Daubert anticipates significant engagement from the automotive sector, it also welcomes visitors from growing industries such as aerospace, semiconductors, medical devices, steel, and bearings. **SD**

Zavenir Daubert India Pvt Ltd
www.zavenir.com
Hall & Stall: 3A/A-112

SMART MANUFACTURING SOLUTIONS

Smart Technologies for Transforming Manufacturing

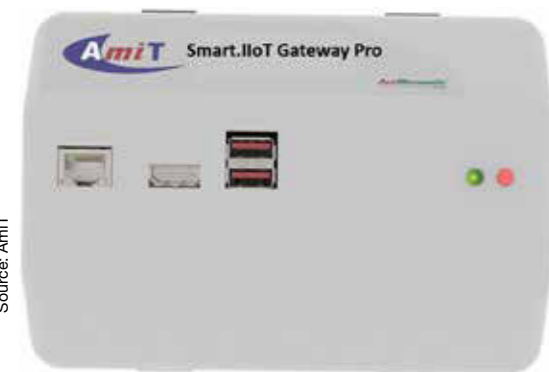

Smart.IIoT Gateway Pro

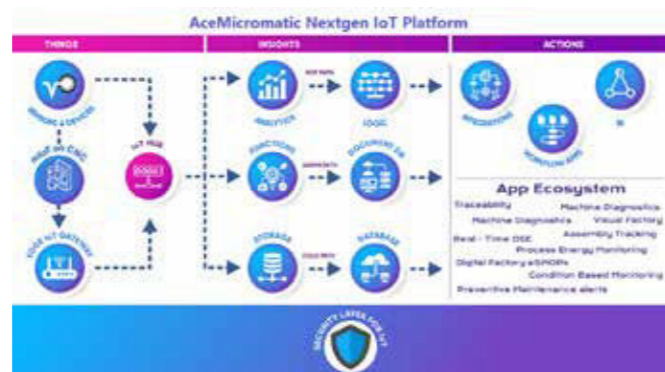

AceMicromatic Nextgen IoT Platform



Smart TruOffset Digital Gauge with Automated Offset Correction

AceMicromatic Manufacturing Intelligence Technologies Pvt Ltd (AmiT)
www.amitpl.com | www.acemicromatic.net | Hall & Stall: 5/C-12

AceMicromatic Manufacturing Intelligence Technologies (AmiT) is part of the AceMicromatic Group, one of the largest machine tool groups in India. AmiT is India's first mover in Industry 4.0 and IIoT products space with over a decade of experience in deploying IIoT solutions. The company has executed over 500+ Enterprise deployments successfully and connected over 25,000+ machines mainly in the discrete manufacturing sector – Automotive, Industrial Equipment, Aerospace & Defence, Tool & Die Mold, and Medical. Winner of multiple prestigious awards, AmiT is focused on Industry 4.0, IIoT, Digital Factory, Smart Factory and Analytics for manufacturing industries worldwide.

Smart Technologies for Transforming Manufacturing

At IMTEX 25, AmiT is showcasing its latest products and solutions for smart manufacturing.

Smart IIoT Gateway (SIG) Pro
 SIG Pro is a full featured edge gateway for IIoT applications. It enables high-value shop manufacturing assets to be connected seamlessly to cloud platforms and provides edge AI capabilities for real-time applications at the production asset. Cloud connectivity options include GSM, Wi-Fi, and LAN. Industrial protocols and interfaces supported include MODBUS, OPC-UA, FOCAS, RS-232, RS-485, Digital I/Os, Analog I/Os, PT-100 thermal and others. Features include smart power management to ensure rugged fail-safe, corruption-free operations, even during transient power failure situations. With its powerful processor, SIG Pro may be deployed at production and shop-floor nodes for enabling digital factory solutions and human interactions.

Smart IIoT Gateway (SIG)
 SIG is a highly optimized IIoT gateway to instantly connect a CNC/PLC machine to a cloud platform. With its low footprint and smart power management, SIG is a cost-effective yet rugged device for scaling up one's Industry 4.0 deployments.

mIoT-CNC
 mIoT-CNC is a CNC control resident software that enables operators to leverage the power of Industry 4.0 right from their CNC control panel, without the need for any connectivity to a server, PC or cloud.

AMG-mIoT Platform
 AMG-mIoT is a full featured IIoT platform to collect real-time data from diverse production sources and turn it into use cases that drive productivity on the shop floor, with enterprise digital workflows and ERP integration. Analytics and insights leverage the power of AI

and Machine Learning to provide rapidly expanding tools and apps to meet any current and future needs of the customer.

Smart TruOffset Digital Gauge with Automated Offset Corrections

This integrated unit deploys the power of digital quality data acquisition, along with sophisticated methods to automatically correct offsets for CNC turning machines. With its rich user interface and integration to MES systems, operators are freed from costly and repetitive manual processes, which lead to better data and process compliance for SPC and SQC. **SD**

GRIPPERS

Gripper by AMF

AMF gripper achieves a fully automatic workpiece change on a machine tool during the machining process. It is changed from the tool magazine of the milling machine and enables workpiece handling between the part storage and the clamping device. It is actuated by means of compressed air, which is routed through the machine spindle. The gripper closes pneumatically and opening takes place by means of spring force. The gripping force can easily be adjusted by means of a pressure control valve and thereby

adapted to the relevant requirements of the workpieces. Easily exchangeable gripper inserts can handle various workpiece geometries. Easy implementation of unmanned shifts lead to greater machine utilization and more flexibility. Additionally, it enables a significant reduction in setup times for small to medium-sized batches. The maximum permitted speed is 20 rpm. It is suitable for both Weldon seat and hydraulic expansion chucks and is designed to operate in ambient temperatures ranging from 0-60 degree celsius. The system is capable of transporting workpieces weighing up to a maximum of 8 kg. The standard supply includes three replacement seals. It is available in two designs to accommodate workpiece sizes up to a max. of 50 mm or 70 mm. Hydraulic version is also available. **SD**

ANDREAS MAIER Workholding Technology Pvt Ltd
www.amf.de
 Hall & Stall: 4A/C-120



Gripper

HOME OF CLAMPING AMF

Source: ANDREAS MAIER Workholding Technology Pvt Ltd

INTERNATIONAL PRESENCE - AFM CLUSTER

Strengthening Collaboration

IMTEX 2025 & Tooltech 2025, as India's premiere machine tool exhibition, has been a successful facilitator in bringing investors together for collaboration and joint ventures. José Pérez Berdud, President, AFM Cluster and CEO, Fagor Automation, attests to the fact and emphasizes its significance, "As the most important machine tool show in the country, IMTEX is a great show and a vibrant meeting point to share information, proposals and opportunities." He points out that despite the uncertainty in Asia, Europe and America due to geopolitical tensions and transformative shifts in sectors such as the automotive, India's industrial landscape remains robust. "The economic data we have about India show good expectations both macroeconomically and industrially," he notes. India's expansive production hubs and significant projects in key sectors reflects its strong industrial development, making the nation a focal point for advanced manufacturing enterprises.

AFM Cluster companies have extensive experience in the country to understand local demands and tailoring their solutions to meet them. "We would like to leverage the exhibition and keep on working and collaborating with Indian companies," Berdud adds. Apart from AFM Cluster and ICEX – the Spanish Institute for Foreign Trade, six Spanish companies renowned for their global presence have participated in the event.

Transformative Potential of Smart Manufacturing

Berdud opines that smart manufacturing is a mix of connected, intelligent and automated equipment that helps produce better products in terms of profitability, sustainability, precision and quality. "Smart manufacturing transforms the traditional analogic industry into a data driven industry," he adds. This transformation enables to consistently plan, simulate and improve different processes, adding value to the client by producing better parts.

Spanish manufacturers are particularly strong at large-size, heavy-duty high-precision solutions that incorporate milling, boring, turning and grinding technologies, for applications in aerospace, energy generation, railway, defence or capital goods sectors, among others. "In AFM Cluster we have built a very powerful industrial environment of 7 associations and more than 800 advanced manufacturing companies, to share the innovation and cooperation to drive smart manufacturing to the next level," he adds, underscoring the collaborative ecosystem fostered by AFM Cluster.

Spain-India Trade Dynamics in the Machine Tool Sector

India consistently ranks among the top ten export destinations for the Spanish machine tool sector, reflecting the country's strategic importance. In 2023, India was the ninth-largest market, with exports totaling €31.44 million. Although this marked a decrease from €45.11 million in 2021, when India ranked sixth, the outlook remains



optimistic. Berdud anticipates similar export figures for 2024, expressing hope to "keep on strengthening the threads of cooperation soon, for which the show is an excellent opportunity." **SD**

José Pérez Berdud
 President, AFM Cluster
 CEO, Fagor Automation

DRIVE THE FUTURE OF MANUFACTURING TECHNOLOGY!

DELHI MACHINE TOOL EXPO 2025

Co-located show **FACTEQ 2025** Factory Equipment Expo

Concurrent Shows **METROLOGY EXPO** **WELDEXPO** **DIGITAL**

8 - 11 May 2025, Bharat Mandapam (Pragati Maidan), New Delhi

BOOK YOUR STALL NOW

Powered by IMTMA, organizer of **IMTEX**

www.mtx.co.in www.facteq.in

**PROPELLING TECHNOLOGY.
PROSPERING LIFE.**



AUTOMOBILE

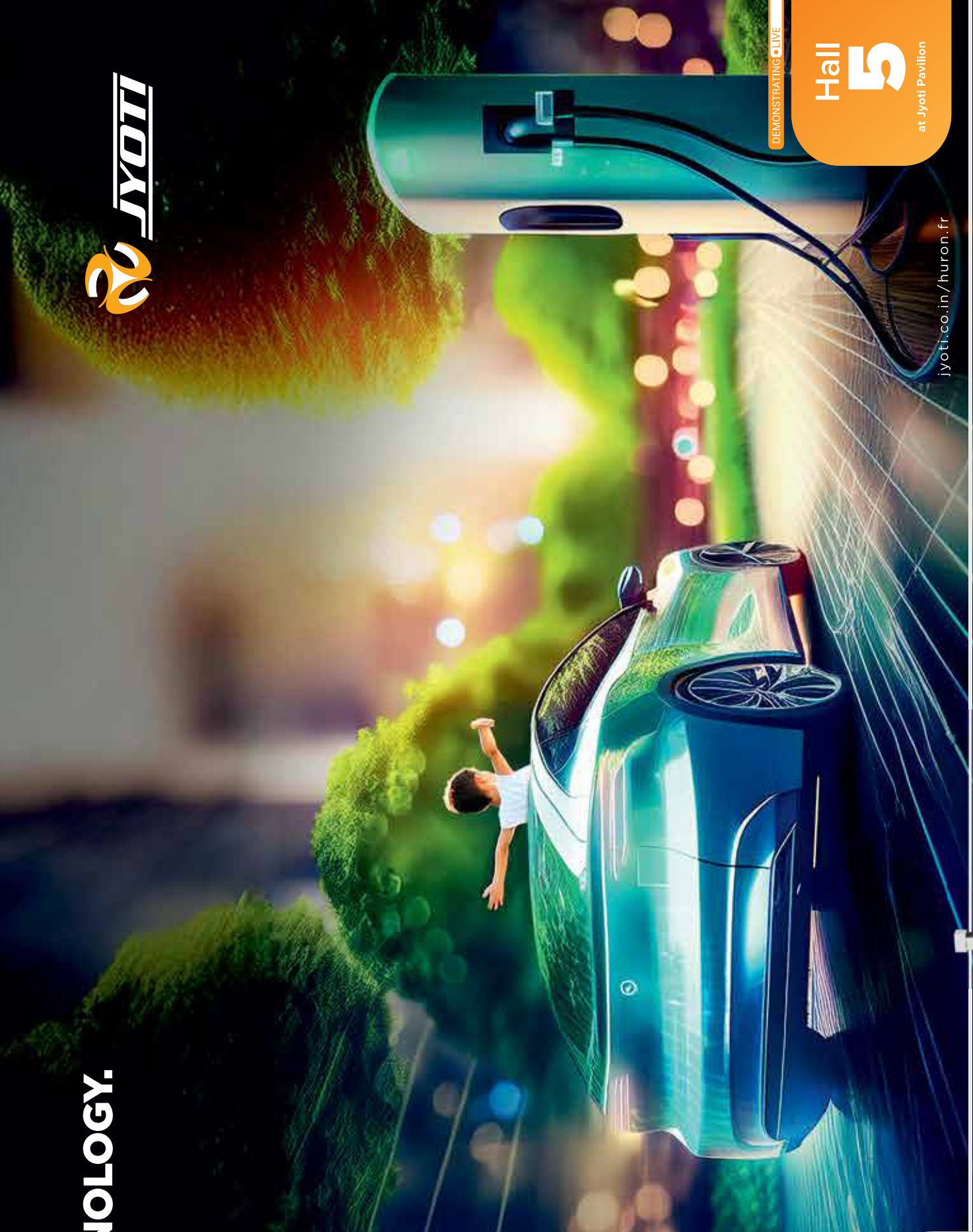

DEMONSTRATING **LIVE**

Hall 5

at Jyoti Pavilion

jyoti.co.in/huron.fr

Widest Range of CNC Machines

- | Turning / Turn-Mill Centers
- | Vertical Machining Centers
- | Horizontal Machining Centers
- | 5-Axis Machining Centers
- | Multi-Tasking Machining Centers

